

Modeling and Development of an Autonomous Underwater Vehicle ARYA for Object Recognition



Aditya Natu, Anuj Badhwar, Vipul Garg, Upasana Biswas, Deepanshu Bansal, Aakash Kumar

Abstract: Arya is an autonomous underwater vehicle (AUV) modeled and developed by team DTU-AUV comprising of undergraduate students from multidisciplinary backgrounds of Delhi Technological University (DTU), India, to participate in an IEEE backed Singapore AUV Challenge (SAUVC). This paper entails the rationale and methodology employed to design and integrate various systems onboard. Significant improvisations have been made in the structural design of the vehicle to enhance its hydrodynamic stability and maneuverability to perform discrete tasks in comparison to the previous vehicles developed by the team. The focus is laid on the embedded and power system to enhance reliability, modularity, and power distribution. The software stack is designed to run in decentralized multi-threaded agent architecture, with the threads handling pressure sensor, cameras, control system, IMU, mission planner each performing input and output operations in continuous loops. PID control algorithms achieve the desired dynamic control. The vision system is devised to monitor the marine environment and detect underwater contoured objects.

Index Terms: AUV, Design, Power System, PID, ROS, Vision.

I. INTRODUCTION

The uninterrupted industrialization in developing countries has not only pushed the development to the shores of the vast water bodies but also increased the dependency on the same for generating hydropower to satisfy the surge in energy demands of the industries and humanity. These majorly include the bridged structures for transport, dams to spawn the hydroelectric energy and the pipelines for supplying oil and gas. The reliability of these structures over a significant period calls for regular monitoring and subsequent

maintenance to prevent catastrophic events. The hefty costs involved in such crewed missions demand cost-effective solutions for long term usage. Autonomous systems assist in setting up such large-scale monitoring programs, which not only reduces human interference in the job but also expands the reach envelope for successfully carrying out the mission. In recent decades, various research and experimental activities have been carried out to develop such autonomous systems, which have shown the potential to execute tasks with ease and augmented accessibility.

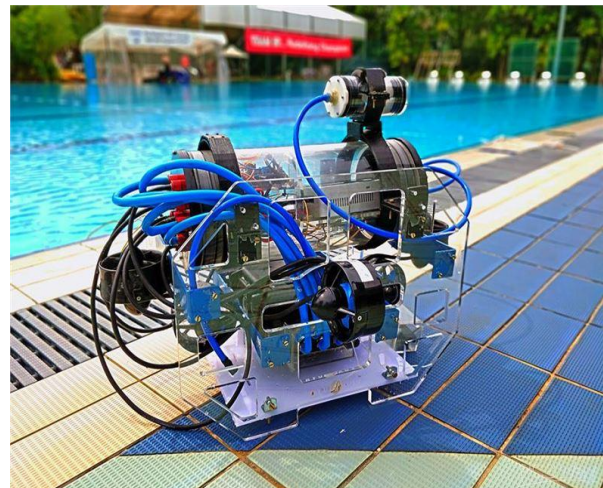

Figure 1: ARYA AUV

A pipeline detection autonomous underwater vehicle (PDAUV), having an advanced vision and acoustical system, was developed recently to inspect the unsatisfactory conditions of dams in China [1]. The severity of the risk associated with the cracks propagating aggressively over the dam walls can be predicted by identifying, evaluating, and categorizing the various cracks based on their length and depth [2]. A hybrid AUV/ROV named TriMARES is designed and developed for periodic monitoring of large dam reservoir [3]. Photomosaic of the walls of the dam has been generated by blending the different images gathered during the inspection [4]. Stereo vision based 3D structural map has been produced for underwater structures for review [5].

This project has been taken up with a similar objective of designing and developing a compact AUV with efficient vision algorithms for detection of contoured structures in the marine environment.

Revised Manuscript Received on 30 July 2019.

* Correspondence Author

Aditya Natu*, Department of Mechanical Engineering, Delhi Technological University, Delhi, India.

Anuj Badhwar, Department of Applied Mathematics, Delhi Technological University, Delhi, India.

Vipul Garg, Department of Mechanical Engineering, Delhi Technological University, Delhi, India.

Upasana Biswas, Department of Electrical Engineering, Delhi Technological University, Delhi, India.

Deepanshu Bansal, Department of Electrical Engineering, Delhi Technological University, Delhi, India.

Aakash Kumar, Department of Mechanical Engineering, Delhi Technological University, Delhi, India.

© The Authors. Published by Blue Eyes Intelligence Engineering and Sciences Publication (BEIESP). This is an [open access](https://creativecommons.org/licenses/by-nc-nd/4.0/) article under the CC-BY-NC-ND license <http://creativecommons.org/licenses/by-nc-nd/4.0/>

The vehicle has been modeled based on foundational design concepts of underwater vehicles while seeking motivation to improvise on the previous vehicle developed by the team, ZYRA [6]. An elegant electronic system is placed onboard, enhancing the reliability and accessibility of the system to debug and repair. Vision algorithms have been devised on a ROS framework for better communication and integration.

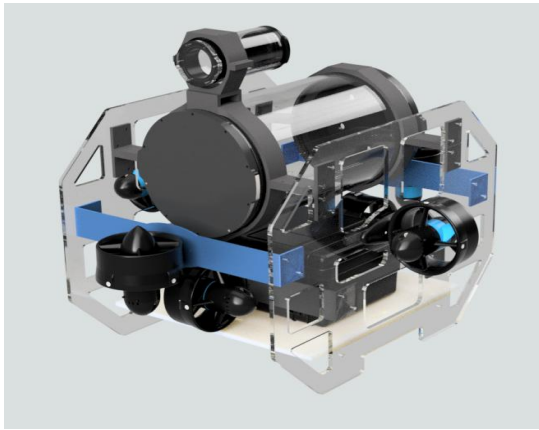

Figure 2: CAD Model of ARYA

This paper discusses the in-depth description of each system designed and integrated into the vehicle. The first section represents the structural design of the vehicle along with validated finite element analysis to assess the structural performance. The successive section describes the electronic stack developed to power and operate the entire modular system. The last section talks about the software framework devised to implement distinctive vision algorithms for precisely carrying out the detection related missions.

II. MECHANICAL DESIGN

The mechanical system of ARYA majorly comprises of the structural framework and the watertight hulls to house the electronic system on-board. The rationale behind the design methodology is to develop a stable vehicle with positive buoyancy, which assists in modeling and operating the control system of the AUV. This is achieved by keeping the desired aspect ratio for hydrodynamic stability and optimally placing the components to maintain the desired relative positions of the center of gravity and buoyancy. The vehicle adopts an open-frame structure to reduce the drag force experienced by it. The design of each subsystem is discussed below in detail.

A. Structural Frame

The AUV employs an acrylic framework to support all the subsystems rigidly. The design of the frame complies to develop a lightweight structure without compromising of the structural strength. The mentioned material is chosen based on its mechanical properties such as strength-to-weight ratio and corrosion resistant abilities. The modeled design has been critically analyzed for its structural performance at greater depths, with emphasis laid on the induced stresses and the factor of safety.

The frame is topologically optimized for trimming the material concerning locations of insignificant stress concentration. The laser cut process efficiently manufactured it and the assembly is done with the mounts of other

subsystems using L-shaped brackets and Allen bolts, made of stainless steel, along with nylon lock nuts to enhance the rigidity of the structure and prevent undue vibrational effects of the system due to loosening of nuts. These bolts have lever arch mechanisms facilitates to apply increased tightening torque [7].

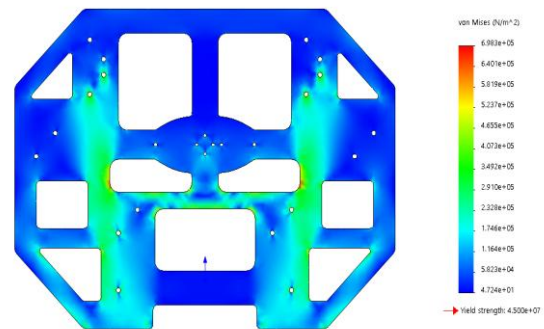

Figure 3: Stress Analysis of Frame

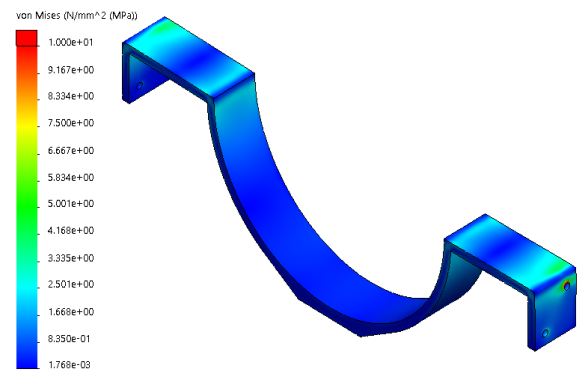

Figure 4: Stress Analysis of Enclosure Clamp

B. Pressure Hulls

The need to enclose the delicate cum costly electronic constituents, namely the sensors and the processing unit calls for developing watertight enclosures that can sustain immense pressure magnitudes. The AUV utilizes cylindrical canisters of 3 and 6-inch diameters, for housing camera and electronic stack respectively, to satisfy the system requirements, specifically due to the uniform pressure distribution over its surface and effective volume utilization [8]. The hulls are made up of hollow acrylic tube, at the end of which aluminum flanges are inserted. End Caps, having intricate cutouts to mount the connectors, are effectively clamped on to the flanges with the help of retaining bolts. O-rings are placed at both facial and radial grooves machined in the flange. These provide an effective seal under varying differential pressures. The batteries are placed in the pelican case set below the electronic hull. The canisters and case cumulatively account for the source of buoyancy, which assists in retrieving the vehicle in case of any sudden failure.

C. Propulsion System

Six T100 Blue Robotics thrusters are used to propel the AUV. The thrusters are placed parallel to the translational axes, namely the surge, heave, and sway. They are oriented as pairs to provide either a couple or combined translational force to maneuver the AUV. The vehicle has five degrees of freedom ruling out the roll motion, which is not required because of the stability the AUV achieves due to the symmetrical and balanced placement of components about the surge axis. This orientation allows for proper maneuverability and controllability of the AUV through asymmetrical thrusting and varying the amount of thrust.

The propulsive efficiency of the vehicle is proportional to the power required to propel, which itself depends on the resistance it experiences during its motion [9]. The open frame enhances this performance characteristic of the vehicle by reducing the frontal area thus reducing the magnitude of pressure drag and also offers smooth flow trajectories of fluid particles through the body which prevents any unwanted deviations on the motion. The validation of the ideology mentioned above is done by performing a CFD analysis of the assembled system of ARYA. The resultant velocity and pressure contours are represented below in Fig.5 & Fig.6.

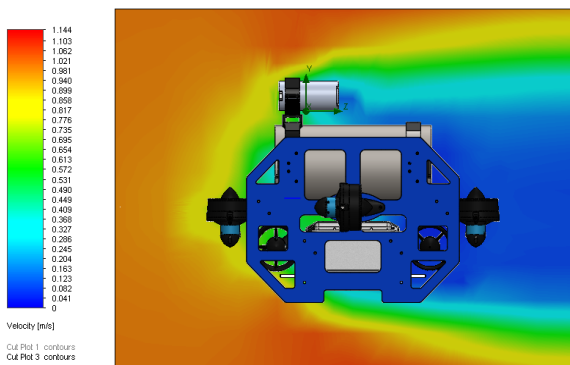

Figure 5: Velocity Contour for Surge Motion

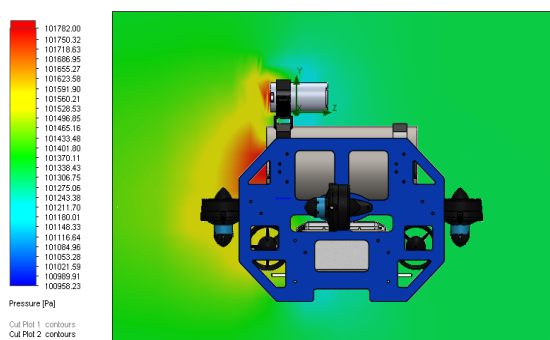

Figure 6: Pressure Contour for Surge Motion

III. EMBEDDED SYSTEMS.

A. Power System

Li-Po batteries have emerged as a promising rechargeable power source for the applications which required high energy density. It is deduced from [10] that the Lithium-ion batteries have relatively very high specific power as compared to other alternatives. They have real advantages which can be utilized by the AUV industry. Low self-discharge increases the life of

the battery. Considering all the positive aspects of Lithium-ion batteries, 3 Lithium polymer batteries with 8000mAh current rating and 11.1V operating voltage have been used in ARYA to power the overall system of the vehicle. The power is distributed in a way such that the crucial components will not shut down unless the mission is completed and therefore two batteries are allocated for the actuators, and one battery is used to power the single board computer, microcontroller, and- sensors. It reduces the load from the power system and ensures the proper functioning of each subsystem.

B. Power Distribution System

It becomes necessary to provide an optimum operating voltage to each component of the integrated system to maximize efficiency. It can be achieved only through an efficient power distribution system which takes a tiny part for its functioning. To reduce the complexity of the electronic structure, highly power optimized step-down and step-up converters have been used. To power the NUC, an adjustable 150W DC-DC boost converter is employed to provide a 19V consistently. Universal Battery Eliminator Circuit (UBEC) has been interfaced with Arduino mega, the microcontroller of the ARYA, as it has in-built filter capacitors. The operating voltage for the actuator of the dropper mechanism is achieved through LM2596 step-down DC-DC voltage converter.

C. Battery Protection Circuit

The cutoff circuit of ARYA is designed keeping in mind the safety of batteries and electronic circuitries. The cutoff circuit consisted of diodes, MOSFETs, comparators, and relays. The diodes are used to prevent back current going to the batteries. Two comparators are used which keeps the battery voltage between a minimum and maximum threshold. Considering 3S Li-Po batteries, one of the comparator is set to a minimum threshold of 3.7V and the other to a maximum threshold of 12V. A combination of MOSFET and relay acted as the switch and made sure that the battery disconnects whenever it malfunctions. The MOSFET and relay are selected, keeping in mind the current required by electronic circuitries (around 30A) and Power distribution board.

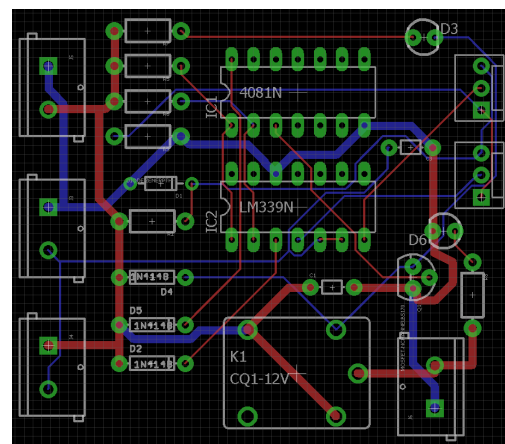
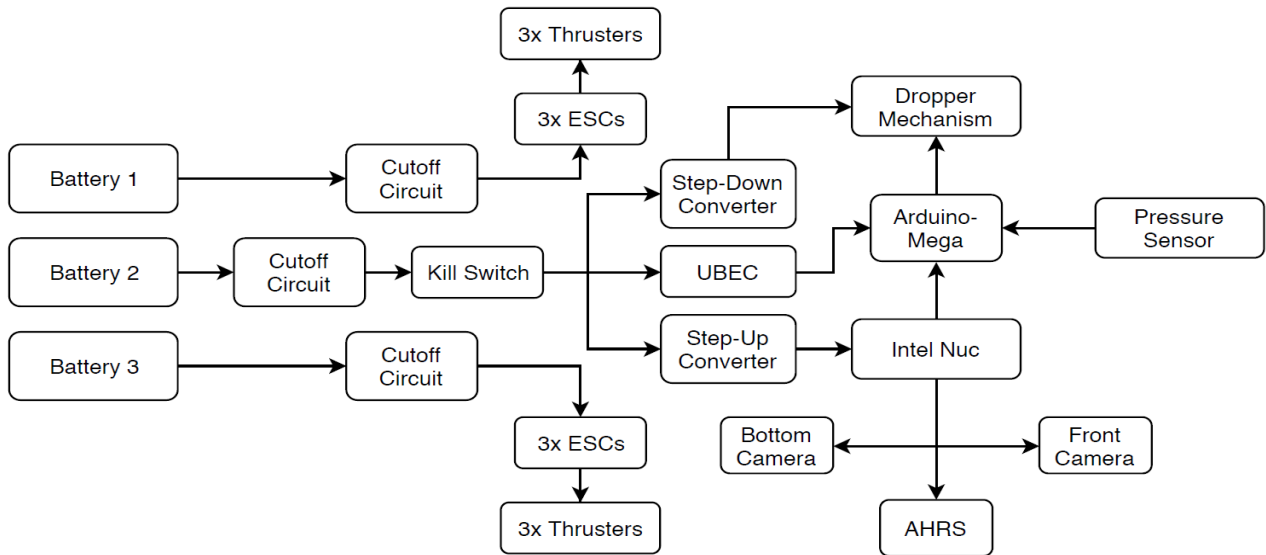

Figure 7: Layout of Battery Protection Board



After the battery is disconnected, switching circuit is used to switch to spare battery. The switching circuit consisted of simple electronic relays which acted as switch.

D. Kill Switch

An external switch is an essential component of every system which obstructs or kills the power supply. It prevents the failure of the whole in case of emergencies. In ARYA, a manually operated T7 series toggle switch from OTTO Is employed between the battery and the processing components. It can withstand 16A current which is adequately high for them. When it is toggled, it

kills the power supply of Arduino, Intel NUC, and the servo actuated dropper mechanism such that no signals can be commanded to the thrusters and eventually they will stop and the ARYA will rise because of its positive buoyancy.

E. Control Units

- **Onboard Single Central Processing Unit:** A light & sturdy single-board computer (Intel NUC corei7) development platform is used as the computing center of the AUV.
- **Microcontroller:** The vehicle uses Arduino Mega 2560 microcontroller based on Atmega 2560. The Arduino receives signals from the SBC via UART mechanism and controls servo such as thrusters.
- **Thruster and motor control:** Brushless thrusters T100 of BLUE ROBOTICS used for providing movement is controlled using Brushed ESC’s (electronic speed control) at different speed levels. The thrusters speed is set by the

highly accurate and stable data. It has onboard hard & soft iron calibration capabilities, which compensates the distortion created from the magnetic field of electric motors and batteries.

- **Pressure Sensor:** Bar30 pressure sensor from Blue Robotics has been incorporated for a precise pressure and temperature measurements, which together give us a resolution of 0.2 mbar.
- **Cameras:** Two Logitech Quick Cam 5000 USB cameras are used for vision sensing. These have meager power requirements and are user-configurable. One covers the front view and other covers bottom view. The cameras are internally mounted, thereby not interfering with the

streamline motion of the body. The vehicle can switch its monitoring between the two according to the tasks.



Figure 9: AHRS [11]

Figure 8: Electronic Architecture of ARYA

microcontroller using PWM. Power is supplied to the thrusters directly from batteries. The ESC’s used are reliable, fast, and compact with proper error indicators.

F. Sensors

- **Attitude Heading and Reference System:** The VN-100 is a high-performance 10 Axis Inertial Measurement Unit (IMU) and Attitude Heading Reference System (AHRS). It provides

handle different tasks according to their functionalities. It is developed using the Kinetic version of the Robot Operating System, which is chosen because of the excellent support available.

IV. SOFTWARE SYSTEM

A. Stack Structure

The stack is divided into the three separate packages which

ROS enabled the design to be modular through discrete and parallel-running nodes with communication implemented through custom messages.

- **Software Module** - It acquires live input feed from the camera for guiding the vehicle as per the task received from the task planner. After multiple preprocessing steps applied to improve the quality of the image, image-processing algorithms are implemented to extract features and acquire the guide data.
- **Navigation Module**- It receives the guide data published by the software module and accordingly calculates the appropriate actuator command values.
- **Control Module** - It has the task of maintaining stable yaw and pitch control of the vehicle through a PID algorithm and feeds the PWM values to the microcontroller.

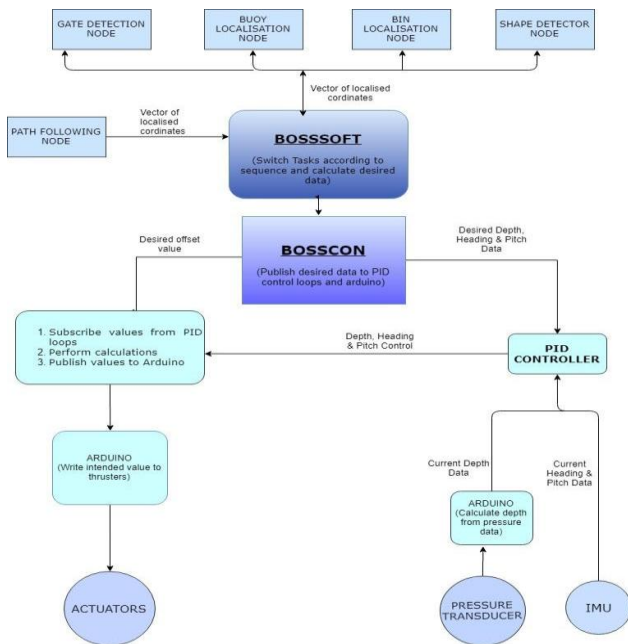

Figure 10: Software Framework of ARYA

B. Image Processing

Due to light absorption, reflection, unsuitable lighting conditions and scattering by water, challenges are faced in developing vision software on images captured in an underwater environment such as distortion in color, contrast is contrast limited adaptive histogram equalization known as CLAHE [12] which is an alternative to adaptive histogram equalization [13] implemented by limiting the enhancement of contrast and in doing so, limits the unwanted amplification of noise.

Color-based segmentation of the task objects is executed by using Otsu's method of adaptive thresholding [14] on the hue-channel of the image in HSV (hue, saturation, value) color space [15-18]. Additional extraction of our desired contour is done by checking the morphological features of all the contours.

Localization and guidance to the vehicle towards the desired point are achieved through the use of a visual serving algorithm known as VisP [19] which produces accurate relative three-dimensional pose estimation of our vehicle using the acquired two-dimensional feature data feedback.

C. PID Control Algorithm

For achieving precise yaw and pitch control, we implement a feedback-based control loop algorithm called proportional-integral-derivative (PID) controller [20-21] on the depth values, pitch angles and yaw angles of the AUV operated on as process variables. The pitch of the vehicle is maintained at a constant stable angle for minimum deviation in vehicle movement while the yaw angle and depth is varied by the navigation module to steering the vehicle towards the desired coordinates. The algorithm consists of three parameters to be tuned- Proportional controller (K_p), Derivative controller (K_d) and Integral controller (K_i) which respectively work on the proportional, derivative and integral value of the error between the desired set point and current state point of the process variable and accordingly vary the actuator commands. The parameters are tuned though Ziegler-Nicholls's tuning method by observing the oscillations of the vehicle in an underwater environment.

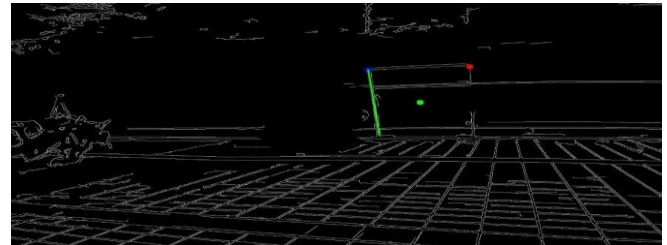

Figure 11: Gate Detection

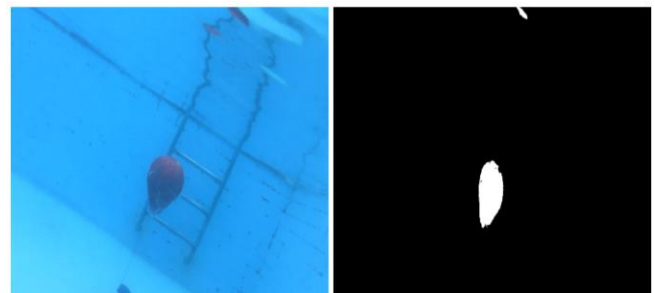

Figure 12: Segmentation of buoy using adaptive thresholding

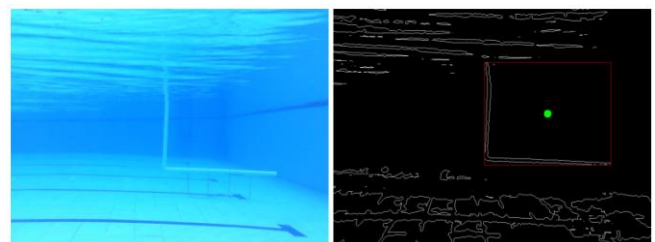

Figure 13: Localization of gate centre using contour validation

V. CONCLUSION

The design of ARYA is a result of rigorous iterations with the commitment to develop a sturdy yet lightweight-cum-compact vehicle. The vehicle meets the industrial standards in terms of safety and eco-friendliness to operate in shallow water,

with a depth range of 5-25m. The assembled framework of the vehicle is utterly stable underwater to hover or maneuver to perform varied functions. A compact electronic stack ensures optimal utilization of space to place all the electronic components in it while avoiding clustering of wire harnesses. The Li-Po batteries efficiently power the stack through the watertight connectors mounted on the endcaps of the pressure hulls. The effective formulations of the software and vision algorithms precisely detect contoured objects and maneuver the vehicle with ease. The PID controllers implemented prevents undesirable deviations in the motion of the AUV. The development of ARYA provides a favorable platform for the team to advance further and improvise the system by integrating distinctive advanced sensors for broadening the application horizons of the AUV in monitoring and detecting the marine habitat and structures.

ACKNOWLEDGMENT

This research and development project is financially supported and supervised by Delhi Technological University. We also thank Pacific Sports Complex, Delhi for letting us availing the facility of swimming pool for testing the vehicle.

REFERENCES

- Jiang, Chun-meng, Lei Wan, and Yu-shan Sun. "Design of motion control system of pipeline detection AUV." *Journal of Central South University* 24, no. 3 (2017): 637-646.
- Neto, Edson Cavalcanti, Rejane C. Sá, Guilherme C. Holanda, Francisco AX da Mota, Antonio T. Varela, André LC Araújo, Ítalo J. Loiola, Rogério Oliveira, R. Auzuir, and Victor Hugo C. de Albuquerque. "Autonomous underwater vehicle to inspect hydroelectric dams." *International Journal of Computer Applications* 101, no. 11 (2014).
- Cruz, Nuno A., Aníbal C. Matos, Rui M. Almeida, Bruno M. Ferreira, and Nuno Abreu. "TriMARES-a hybrid AUV/ROV for dam inspection." In *OCEANS'11 MTS/IEEE KONA*, pp. 1-7. IEEE, 2011.
- Neto, Edson Cavalcanti, Rejane C. Sá, Guilherme C. Holanda, Francisco AX da Mota, Antonio T. Varela, André LC Araújo, Ítalo J. Loiola, Rogério Oliveira, R. Auzuir, and Victor Hugo C. de Albuquerque. "Autonomous underwater vehicle to inspect hydroelectric dams." *International Journal of Computer Applications* 101, no. 11 (2014).
- Negahdaripour, Shahriar, and Pezhman Firoozfam. "Multi-camera inspection of underwater structures." U.S. Patent 7,496,226, issued February 24, 2009.
- Gupta, Aayush, Vatsal Rustagi, Raj Kumar Saini, Akshay Jain, Prateek Murgai, Aditya Rastogi, Pronnoy Goswami et al. "Delhi Technological University: Design and Development of the Littoral AUV Zyra 2.0."
- Inoxmare. "Hexagon Socket Screws – What Benefits?" <https://blog.inoxmare.com/eng/2016/03/03/hexagon-socket-screws-wh-at-benefits/> (accessed June 1, 2019).
- Moore, Steven W., Harry Bohm, Vickie Jensen, and Nola Johnston. *Underwater robotics: science, design & fabrication*. Monterey, CA: Marine Advanced Technology Education (MATE) Center, 2010.
- Diesel, M. A. N. "Turbo, Basic principles of ship propulsion. December 2011. Copenhagen, Denmark."
- Morris, Melissa, and Sabri Tosunoglu. "Comparison of rechargeable battery technologies." In *ASME Early Career Technical Conference, Atlanta, Georgia*, pp. 2-12. 2012.
- Vectornav. "VN-100 IMU/AHRS." [vectornav.com. https://www.vectornav.com/products/vn-100](https://www.vectornav.com/products/vn-100) (accessed Jan. 1, 2018).
- Yadav, Garima, Saurabh Maheshwari, and Anjali Agarwal. "Contrast limited adaptive histogram equalization based enhancement for real time video system." In *2014 International Conference on Advances in Computing, Communications and Informatics (ICACCI)*, pp. 2392-2397. IEEE, 2014.
- Pizer, Stephen M., E. Philip Amburn, John D. Austin, Robert Cromartie, Ari Geselowitz, Trey Greer, Bart ter Haar Romeny, John B. Zimmerman, and Karel Zuiderveld. "Adaptive histogram equalization

- and its variations." *Computer vision, graphics, and image processing* 39, no. 3 (1987): 355-368.
- Priya, M. S., and Dr GM Kadhar Nawaz. "Multilevel Image Thresholding using OTSU's Algorithm in Image Segmentation." *International Journal of Scientific & Engineering Research* 8, no. 5 (2017).
 - Liu, Zhong, Weihai Chen, Yuhua Zou, and Cun Hu. "Regions of interest extraction based on HSV color space." In *IEEE 10th International Conference on Industrial Informatics*, pp. 481-485. IEEE, 2012.
 - Wikipedia. "Color space" https://www.wikipedia.org.https://en.wikipedia.org/wiki/Color_space100 (accessed Jan. 10, 2018).
 - Wikipedia. "HSL and HSV" https://www.wikipedia.org.https://en.wikipedia.org/wiki/HSL_and_HSV (accessed Jan. 10, 2018).
 - Sural, Shamik & Vadivel, A & Majumdar, Arun. (2005). Histogram Generation from the HSV Color Space.
 - Marchand, Eric. "Visp: A software environment for eye-in-hand visual servoing." In *Proceedings 1999 IEEE International Conference on Robotics and Automation (Cat. No. 99CH36288C)*, vol. 4, pp. 3224-3229. IEEE, 1999.
 - Wikipedia. "PID controller" https://www.wikipedia.org.https://en.wikipedia.org/wiki/PID_controller (accessed Jan. 8, 2018).
 - ROS.org. "pid" [http://wiki.ros.org.http://wiki.ros.org.pid](http://wiki.ros.org.http://wiki.ros.org.http://wiki.ros.org/pid) (accessed Jan. 10, 2018).

AUTHORS PROFILE



Mr. Aditya Natu is a Delhi Technological University graduate having pursued Production and Industrial Engineering, and embarking his career in Planys Technologies as a Mechanical Design Engineer. He has been actively involved in various technical projects namely on Autonomous Underwater Vehicle and Racing Go-Kart and has lead the respective teams to various national and international competitions. He has successfully published research papers based on the work pursued by him on the Structural Design of Go-Karts and recently on Regenerative Braking in Commercial Vehicles. He is currently pursuing research on Design and Controls of Underwater Vehicles, and have successfully completed a research internship at CSIR National Institute of Oceanography, India.



Mr. Anuj Badhwar is a Delhi Technological University graduate, and currently working in Amazon as a Software Development Engineer. He is an avid computer vision and deep learning researcher for the past 2 years, and has published a paper in NTIRE, CVPRW 2019 in the field of Deep Learning.



Mr. Vipul Garg is a Mechanical Engineering student at Delhi Technological University (formerly DCE). He is currently working as team leader and embedded department head in Team DTU-AUV. For the last two years, He has been pursuing active research in the field of

mechatronics.



Ms Upasana Biswas is an Electrical Engineering student at Delhi Technological University (formerly DCE). She has been pursuing active research in the field of computer vision and has worked in the software department of Team DTU-AUV.



Mr. Deepanshu Bansal is currently pursuing Electrical Engineering from Delhi Technological University. He has worked in the Embedded and control Department of Autonomous Underwater Vehicles for two years. And is currently working on navigation of Autonomous Grounded Vehicles using state machine model.



Mr. Aakash Kumar is a Mechanical Engineering student at Delhi Technological University (formerly DCE). He has been in a research field from last two years and published technical and review papers in the field of Autonomous Underwater Vehicles and in the field of

Hydrogen fuel cell technology (published in SAE WCX 2018).